

HydroLynx Systems, Inc.

Model 50386D-RP
Decoder and Repeater

Instruction Manual

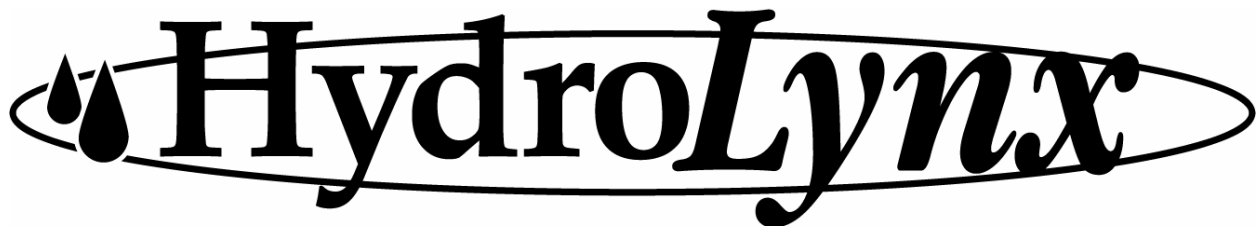

Document No: A102683
Document Revision Date: August, 2006

Receiving and Unpacking

Carefully unpack all components and compare to the packing list. Notify HydroLynx Systems immediately concerning any discrepancy. Inspect equipment to detect any damage that may have occurred during shipment. In the event of damage, any claim for loss must be filed immediately with the carrier by the consignee. If the equipment was shipped via Parcel Post or UPS, contact HydroLynx Systems for instructions.

Returns

If equipment is to be returned to the factory for any reason, call HydroLynx between 8:00 a.m. and 4:00 p.m. Pacific Time to request a Return Authorization Number (RA#). Include with the returned equipment a description of the problem and the name, address, and daytime phone number of the sender. Carefully pack the equipment to prevent damage during the return shipment. Call HydroLynx for packing instructions in the case of delicate or sensitive items. If packing facilities are not available, take the equipment to the nearest Post Office, UPS, or other freight service and obtain assistance with packaging. Please write the RA# on the outside of the box.

Warranty

HydroLynx Systems warrants that its products are free from defects in material and workmanship under normal use and service for a period of one year from the date of shipment from the factory. HydroLynx Systems' obligations under this warranty are limited to, at HydroLynx's option: (i) replacing; or (ii) repairing; any product determined to be defective. In no case shall HydroLynx Systems' liability exceed product's original purchase price. This warranty does not apply to any equipment that has been repaired or altered, except by HydroLynx Systems, or that has been subjected to misuse, negligence, or accident. It is expressly agreed that this warranty will be in lieu of all warranties of fitness and in lieu of the warranty of merchantability.

Address

**HydroLynx Systems, Inc.
950 Riverside Pkwy., Suite 10
West Sacramento, CA 95605
Phone: (916) 374-1800
Fax: (916) 374-1877
E-mail: hydro@hydrolynx.com**

Copyright 8 2006 by HydroLynx Systems, Inc.

TABLE OF CONTENTS

SECTION NO.	PAGE NO.
1.0 INTRODUCTION.....	5
1.1 General Description	5
1.2 Equipment Included.....	5
1.3 Specifications	5
2.0 INSTALLATION.....	5
2.1 Site Selection	5
2.2 Connections	5
2.3 Mounting.....	6
3.0 THEORY OF OPERATION	6
3.1 Fused AC input.....	6
3.2 Power On Light.....	6
3.3 Inputs/Outputs	6
4.0 TESTING AND MAINTENANCE	7
4.1 Testing.....	7
4.1.1 RS232 Signal.....	7
4.1.2 Input Signal.....	7
4.2 Maintenance.....	7
5.0 FORMS AND DRAWINGS	7

1.0 INTRODUCTION

1.1 General Description

The HydroLynx Model 50386R/D-RP Receiver/Decoder and Repeater combines the features of an ALERT Receiver/Decoder with a repeater. The Alert Receiver/Decoder receives ALERT data transmissions from the remote site and provides an RS232 output to the central site computer. The ALERT repeater re-transmits received ALERT reports and can also transmit control commands from the central site computer. The 50386 multiple communication pathway feature provides the ability to process and re-format data. This enables data sharing across various data collection systems.

1.2 Equipment Included

50386D-RP
AC/DC Power Supply
RS232 Cable 25M-9F

1.3 Specifications

Enclosure:	Desktop
Decoder processor:	See 50386DCU manual
Power required:	10 to 16 Vdc
Current drain:	< 150 mA
Input:	6 pin MS male Rotated
Output:	Two, Four or Six DB25 RS232 female
Operating temperature:	-40 to 85 °C
Humidity:	0 to 95 %, non-condensing
Size:	7.25 in. x 2.75 in. x 9 in.
Weight:	3 lbs.

2.0 INSTALLATION

The 50386R/D-RP Receiver/Decoder and Repeater is composed of two devices: the radio repeater and the modulator/demodulator. The 50386R-RP is installed at or near the antenna tower. The 50386D-RP is installed at or near the operator's office.

2.1 Site Selection

The 50386D-RP decoder must be installed within ten feet of the central site computer.

2.2 Connections

All wiring connections are located on the back panel.

CAUTION: Use shielded cable. Connect the shield to Earth Ground at the receiver.

- ! Plug the decoder signal cable into the **Tone In** jack.
- ! Attach the computer cable to either of the standard 25 pin male RS232 connectors.
- ! Attach the power cord to the AC plug.
- ! Plug power cord into the central site's electrical power outlet. For best results, use surge protection and a battery backed power supply for all computer power connections.

2.3 Mounting

The 50386D-RP is designed for "desktop" indoor use and installation.

3.0 THEORY OF OPERATION

The 50386D-RP Decoder receives audio signals from the 50386R-RP Receiver and decodes these signals into RS232 signals. The decoder has tone filters for interference and noise elimination to ensure accurate input to the computer. The decoder is powered by 115 Vac and should use the central site's uninterruptible power supply (UPS) for back-up.

3.1 Fused AC input

Fuse is 1/4 amp.

CAUTION: Before replacing the fuse, always unplug AC power cord.

3.2 Power On Light

The power light is lighted whenever AC power is applied. Check the fuse if the light is off when the unit is plugged into AC power.

3.3 Inputs/Outputs

The 50386D-RP receives ALERT format FSK tones as its input signal. The FSK modem circuitry converts these tones into RS232 logic level signals for output to a computer. The ALERT signal format is 2133 Hz for a logical "1" and 1920 Hz for a logical "0". The output transmission rate is 300 baud.

4.0 TESTING AND MAINTENANCE

CAUTION: HydroLynx recommends service be performed by trained personnel only.

4.1 Testing

4.1.1 RS232 Signal

- ! Attach an oscilloscope to the RS232 cable port. Pin 3 is signal and Pin 7 is ground.
- ! Verify that the standby voltage (no transmission) is -12 Vdc. The typical voltage is between -16 to -20 Vdc.
- ! Initiate a transmission to the receiver.
- ! Verify that the signal is a -12 Vdc (typical: -16 to -20) to +12 Vdc (typical 12 to 16) volt square wave.

4.1.2 Input Signal

- ! Attach oscilloscope to the receiver/decoder signal cable.
- ! Initiate a transmission to the receiver.
- ! Verify that the signal is an 800 mVpp tone.
- ! Refer to 50386R manual for adjustment.

4.2 Maintenance

The 50386D-RP is essentially a low maintenance unit, however, cables and connectors should be checked periodically for loose connections and wear.

5.0 FORMS AND DRAWINGS

AC102369 Outline - Decoder
AC107511 Wiring Diagram - Chassis
AC107510 Assembly - PCB
AC107484 Transmission Formats

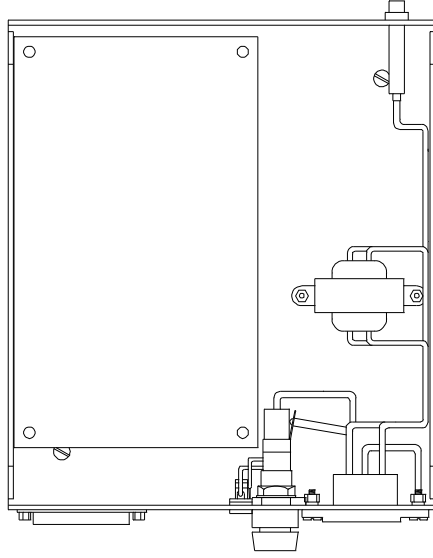
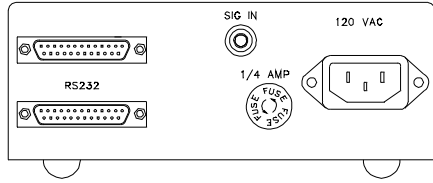

CHASSIS SHOWN WITH COVER REMOVED

0001	CHANGE TO SINGLE XFORMER	03/31/00
ECN#	DESCRIPTION	DATE
MODEL USAGE		
MODEL NO.	5051-DE	
TITLE	DECODER	
DATE	03/31/00	
DRWN BY	TY KIM	
CHECKED BY		
SIZE	B	DRWG NO. AC102369
REV	D	

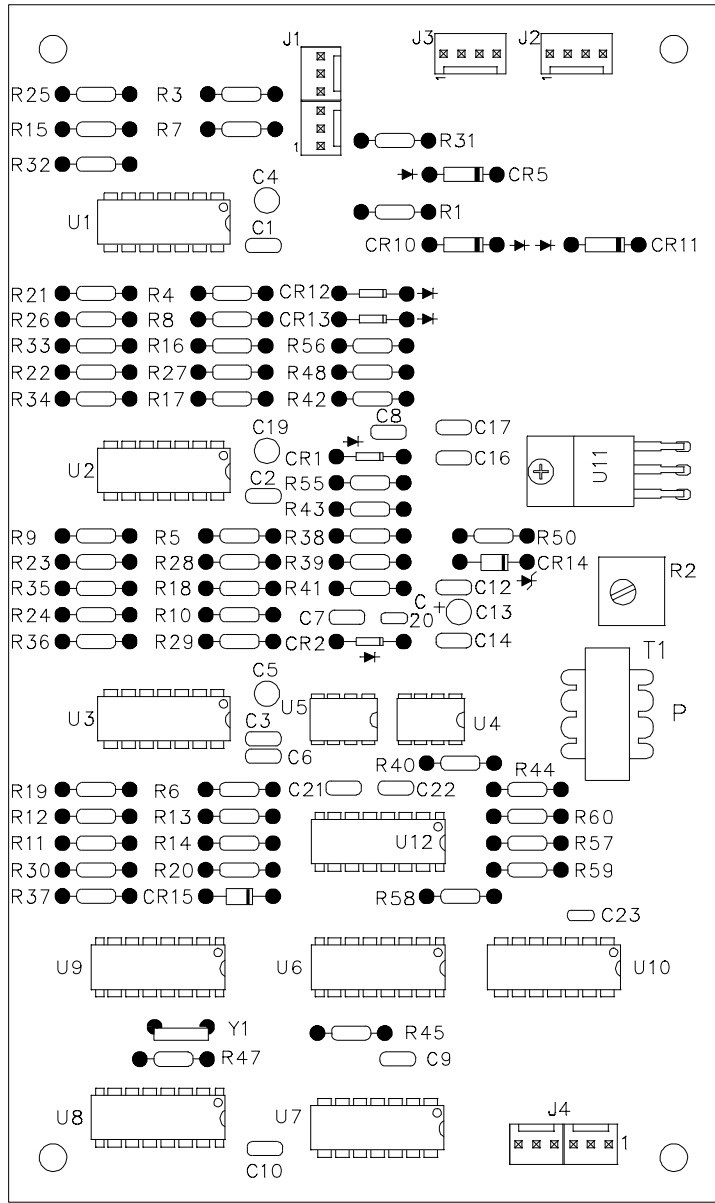

- NOTES: 1. SCHEMATIC IS DRAWING NO. AC107509
 2. WIRING DIAGRAM IS DRAWING AC107483.

N/A	REDRAWN ON NEW BOARDER	10/7/98
NL055	ACAD REDRAWN	4/12/95
ECN #	DESCRIPTION	DATE
MODEL USAGE		
MODEL NO. 5051D, 5062		
TITLE PCB, FSK MODEM		
DWG TYPE ASSEMBLY		
DRAWN BY MYERS	DATE 10/7/98	SIZE A
CHECKED BY	DATE	DWG NO. AC107510
		REV B

